

Name :

Form :



**BAHAGIAN PENGURUSAN SEKOLAH BERASRAMA PENUH
DAN SEKOLAH KECEMERLANGAN
KEMENTERIAN PELAJARAN MALAYSIA**

PEPERIKSAAN PERCUBAAN SPM

3472 / 1

ADDITIONAL MATHEMATICS

Kertas 1

Ogos 2011

2 jam

Dua jam

**JANGAN BUKA KERTAS SOALAN INI
SEHINGGA DIBERITAHU**

1. *Tulis nama dan tingkatan anda pada ruangan yang disediakan.*
2. *Kertas soalan ini adalah dalam dwibahasa.*
3. *Soalan dalam bahasa Inggeris mendahului soalan yang sepadan dalam bahasa Melayu.*
4. *Calon dibenarkan menjawab keseluruhan atau sebahagian soalan sama ada dalam bahasa Inggeris atau bahasa Melayu.*
5. *Calon dikehendaki membaca maklumat di halaman belakang kertas soalan ini.*

<i>Untuk Kegunaan Pemeriksa</i>		
Soalan	Markah Penuh	Markah Diperolehi
1	3	
2	3	
3	3	
4	3	
5	3	
6	3	
7	3	
8	4	
9	4	
10	4	
11	3	
12	3	
13	4	
14	3	
15	3	
16	3	
17	4	
18	2	
19	3	
20	3	
21	3	
22	3	
23	3	
24	3	
25	4	
TOTAL	80	

Kertas soalan ini mengandungi **24** halaman bercetak

BLANK PAGE
HALAMAN KOSONG

The following formulae may be helpful in answering the questions. The symbols given are the ones commonly used.

ALGEBRA

$$1 \quad x = \frac{-b \pm \sqrt{b^2 - 4ac}}{2a}$$

$$2 \quad a^m \times a^n = a^{m+n}$$

$$3 \quad a^m \div a^n = a^{m-n}$$

$$4 \quad (a^m)^n = a^{mn}$$

$$5 \quad \log_a mn = \log_a m + \log_a n$$

$$6 \quad \log_a \frac{m}{n} = \log_a m - \log_a n$$

$$7 \quad \log_a m^n = n \log_a m$$

$$8 \quad \log_a b = \frac{\log_c b}{\log_c a}$$

$$9 \quad T_n = a + (n-1)d$$

$$10 \quad S_n = \frac{n}{2}[2a + (n-1)d]$$

$$11 \quad T_n = ar^{n-1}$$

$$12 \quad S_n = \frac{a(r^n - 1)}{r - 1} = \frac{a(1 - r^n)}{1 - r}, \quad (r \neq 1)$$

$$13 \quad S_\infty = \frac{a}{1 - r}, \quad |r| < 1$$

CALCULUS

$$1 \quad y = uv, \quad \frac{dy}{dx} = u \frac{dv}{dx} + v \frac{du}{dx}$$

$$2 \quad y = \frac{u}{v}, \quad \frac{dy}{dx} = \frac{v \frac{du}{dx} - u \frac{dv}{dx}}{v^2},$$

$$3 \quad \frac{dy}{dx} = \frac{dy}{du} \times \frac{du}{dx}$$

4 Area under a curve

$$= \int_a^b y \, dx \quad \text{or}$$

$$= \int_a^b x \, dy$$

5 Volume generated

$$= \int_a^b \pi y^2 \, dx \quad \text{or}$$

$$= \int_a^b \pi x^2 \, dy$$

GEOMETRY

$$1 \quad \text{Distance} = \sqrt{(x_2 - x_1)^2 + (y_2 - y_1)^2}$$

2 Midpoint

$$(x, y) = \left(\frac{x_1 + x_2}{2}, \frac{y_1 + y_2}{2} \right)$$

$$3 \quad |r| = \sqrt{x^2 + y^2}$$

$$4 \quad \hat{r} = \frac{xi + yj}{\sqrt{x^2 + y^2}}$$

5 A point dividing a segment of a line

$$(x, y) = \left(\frac{nx_1 + mx_2}{m + n}, \frac{ny_1 + my_2}{m + n} \right)$$

6 Area of triangle

$$= \frac{1}{2} |(x_1 y_2 + x_2 y_3 + x_3 y_1) - (x_2 y_1 + x_3 y_2 + x_1 y_3)|$$

STATISTIC

$$1 \quad \bar{x} = \frac{\sum x}{N}$$

$$2 \quad \bar{x} = \frac{\sum fx}{\sum f}$$

$$3 \quad \sigma = \sqrt{\frac{\sum (x - \bar{x})^2}{N}} = \sqrt{\frac{\sum x^2}{N} - \bar{x}^2}$$

$$4 \quad \sigma = \sqrt{\frac{\sum f(x - \bar{x})^2}{\sum f}} = \sqrt{\frac{\sum fx^2}{\sum f} - \bar{x}^2}$$

$$5 \quad m = L + \left[\frac{\frac{1}{2}N - F}{f_m} \right] C$$

$$6 \quad I = \frac{Q_1}{Q_0} \times 100$$

$$7 \quad \bar{I} = \frac{\sum w_1 I_1}{\sum w_1}$$

$$8 \quad {}^n P_r = \frac{n!}{(n-r)!}$$

$$9 \quad {}^n C_r = \frac{n!}{(n-r)!r!}$$

$$10 \quad P(A \cup B) = P(A) + P(B) - P(A \cap B)$$

$$11 \quad P(X=r) = {}^n C_r p^r q^{n-r}, \quad p + q = 1$$

$$12 \quad \text{Mean } \mu = np$$

$$13 \quad \sigma = \sqrt{npq}$$

$$14 \quad z = \frac{x - \mu}{\sigma}$$

TRIGONOMETRY

$$1 \quad \text{Arc length, } s = r\theta$$

$$2 \quad \text{Area of sector, } L = \frac{1}{2} r^2 \theta$$

$$3 \quad \sin^2 A + \cos^2 A = 1$$

$$4 \quad \sec^2 A = 1 + \tan^2 A$$

$$5 \quad \operatorname{cosec}^2 A = 1 + \cot^2 A$$

$$6 \quad \sin 2A = 2 \sin A \cos A$$

$$7 \quad \begin{aligned} \cos 2A &= \cos^2 A - \sin^2 A \\ &= 2 \cos^2 A - 1 \\ &= 1 - 2 \sin^2 A \end{aligned}$$

$$8 \quad \tan 2A = \frac{2 \tan A}{1 - \tan^2 A}$$

$$9 \quad \sin(A \pm B) = \sin A \cos B \pm \cos A \sin B$$

$$10 \quad \cos(A \pm B) = \cos A \cos B \mp \sin A \sin B$$

$$11 \quad \tan(A \pm B) = \frac{\tan A \pm \tan B}{1 \mp \tan A \tan B}$$

$$12 \quad \frac{a}{\sin A} = \frac{b}{\sin B} = \frac{c}{\sin C}$$

$$13 \quad a^2 = b^2 + c^2 - 2bc \cos A$$

$$14 \quad \text{Area of triangle} = \frac{1}{2} ab \sin C$$

THE UPPER TAIL PROBABILITY Q(z) FOR THE NORMAL DISTRIBUTION N(0,1)
KEBARANGKALIAN Hujung Atas Q(z) BAGI TABURAN NORMAL N(0, 1)

z											Minus / Tolak								
	0	1	2	3	4	5	6	7	8	9	1	2	3	4	5	6	7	8	9
0.0	0.5000	0.4960	0.4920	0.4880	0.4840	0.4801	0.4761	0.4721	0.4681	0.4641	4	8	12	16	20	24	28	32	36
0.1	0.4602	0.4562	0.4522	0.4483	0.4443	0.4404	0.4364	0.4325	0.4286	0.4247	4	8	12	16	20	24	28	32	36
0.2	0.4207	0.4168	0.4129	0.4090	0.4052	0.4013	0.3974	0.3936	0.3897	0.3859	4	8	12	15	19	23	27	31	35
0.3	0.3821	0.3783	0.3745	0.3707	0.3669	0.3632	0.3594	0.3557	0.3520	0.3483	4	7	11	15	19	22	26	30	34
0.4	0.3446	0.3409	0.3372	0.3336	0.3300	0.3264	0.3228	0.3192	0.3156	0.3121	4	7	11	15	18	22	25	29	32
0.5	0.3085	0.3050	0.3015	0.2981	0.2946	0.2912	0.2877	0.2843	0.2810	0.2776	3	7	10	14	17	20	24	27	31
0.6	0.2743	0.2709	0.2676	0.2643	0.2611	0.2578	0.2546	0.2514	0.2483	0.2451	3	7	10	13	16	19	23	26	29
0.7	0.2420	0.2389	0.2358	0.2327	0.2296	0.2266	0.2236	0.2206	0.2177	0.2148	3	6	9	12	15	18	21	24	27
0.8	0.2119	0.2090	0.2061	0.2033	0.2005	0.1977	0.1949	0.1922	0.1894	0.1867	3	5	8	11	14	16	19	22	25
0.9	0.1841	0.1814	0.1788	0.1762	0.1736	0.1711	0.1685	0.1660	0.1635	0.1611	3	5	8	10	13	15	18	20	23
1.0	0.1587	0.1562	0.1539	0.1515	0.1492	0.1469	0.1446	0.1423	0.1401	0.1379	2	5	7	9	12	14	16	19	21
1.1	0.1357	0.1335	0.1314	0.1292	0.1271	0.1251	0.1230	0.1210	0.1190	0.1170	2	4	6	8	10	12	14	16	18
1.2	0.1151	0.1131	0.1112	0.1093	0.1075	0.1056	0.1038	0.1020	0.1003	0.0985	2	4	6	7	9	11	13	15	17
1.3	0.0968	0.0951	0.0934	0.0918	0.0901	0.0885	0.0869	0.0853	0.0838	0.0823	2	3	5	6	8	10	11	13	14
1.4	0.0808	0.0793	0.0778	0.0764	0.0749	0.0735	0.0721	0.0708	0.0694	0.0681	1	3	4	6	7	8	10	11	13
1.5	0.0668	0.0655	0.0643	0.0630	0.0618	0.0606	0.0594	0.0582	0.0571	0.0559	1	2	4	5	6	7	8	10	11
1.6	0.0548	0.0537	0.0526	0.0516	0.0505	0.0495	0.0485	0.0475	0.0465	0.0455	1	2	3	4	5	6	7	8	9
1.7	0.0446	0.0436	0.0427	0.0418	0.0409	0.0401	0.0392	0.0384	0.0375	0.0367	1	2	3	4	4	5	6	7	8
1.8	0.0359	0.0351	0.0344	0.0336	0.0329	0.0322	0.0314	0.0307	0.0301	0.0294	1	1	2	3	4	4	5	6	6
1.9	0.0287	0.0281	0.0274	0.0268	0.0262	0.0256	0.0250	0.0244	0.0239	0.0233	1	1	2	2	3	4	4	5	5
2.0	0.0228	0.0222	0.0217	0.0212	0.0207	0.0202	0.0197	0.0192	0.0188	0.0183	0	1	1	2	2	3	3	4	4
2.1	0.0179	0.0174	0.0170	0.0166	0.0162	0.0158	0.0154	0.0150	0.0146	0.0143	0	1	1	2	2	2	3	3	4
2.2	0.0139	0.0136	0.0132	0.0129	0.0125	0.0122	0.0119	0.0116	0.0113	0.0110	0	1	1	1	2	2	2	3	3
2.3	0.0107	0.0104	0.0102								0	1	1	1	1	2	2	2	2
				0.00990	0.00964	0.00939	0.00914				3	5	8	10	13	15	18	20	23
								0.00889	0.00866	0.00842	2	5	7	9	12	14	16	16	21
2.4	0.00820	0.00798	0.00776	0.00755	0.00734						2	4	6	8	11	13	15	17	19
						0.00714	0.00695	0.00676	0.00657	0.00639	2	4	6	7	9	11	13	15	17
2.5	0.00621	0.00604	0.00587	0.00570	0.00554	0.00539	0.00523	0.00508	0.00494	0.00480	2	3	5	6	8	9	11	12	14
2.6	0.00466	0.00453	0.00440	0.00427	0.00415	0.00402	0.00391	0.00379	0.00368	0.00357	1	2	3	5	6	7	9	9	10
2.7	0.00347	0.00336	0.00326	0.00317	0.00307	0.00298	0.00289	0.00280	0.00272	0.00264	1	2	3	4	5	6	7	8	9
2.8	0.00256	0.00248	0.00240	0.00233	0.00226	0.00219	0.00212	0.00205	0.00199	0.00193	1	1	2	3	4	4	5	6	6
2.9	0.00187	0.00181	0.00175	0.00169	0.00164	0.00159	0.00154	0.00149	0.00144	0.00139	0	1	1	2	2	3	3	4	4
3.0	0.00135	0.00131	0.00126	0.00122	0.00118	0.00114	0.00111	0.00107	0.00104	0.00100	0	1	1	2	2	2	3	3	4

$$f(z) = \frac{1}{\sqrt{2\pi}} \exp\left(-\frac{1}{2}z^2\right)$$

$$Q(z) = \int_k^{\infty} f(z) dz$$

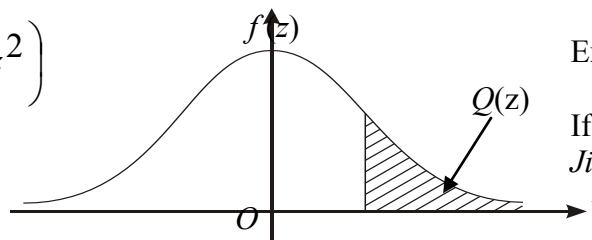

Example / Contoh:

If $X \sim N(0, 1)$, then $P(X > k) = Q(k)$
 Jika $X \sim N(0, 1)$, maka $P(X > k) = Q(k)$

SULIT

For
examiner's
use only

Answer **all** questions.
Jawab semua soalan.

1. Diagram 1 shows the function $f : x \rightarrow \frac{x+3}{x}, x \neq 0$.
Rajah 1 menunjukkan fungsi $f : x \rightarrow \frac{x+3}{x}, x \neq 0$.

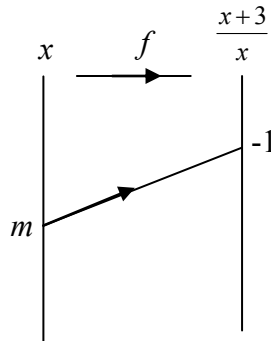

Diagram 1
Rajah 1

Find

Cari

- (a) the value of m
nilai m
- (b) image of -2
imej bagi -2

[3 marks]

[3 markah]

Answer/*Jawapan* :

(a)

(b)

1

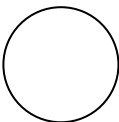
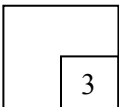

SULIT**3472/1***For
examiner's
use only*

2. Given that the function $h : x \rightarrow 2x - 3$ dan $k : x \rightarrow (x - 2)^2 + 1$.
Diberi fungsi $h : x \rightarrow 2x - 3$ dan $k : x \rightarrow (x - 2)^2 + 1$.

Find
Cari

(a) $h^{-1}(x)$

(b) $h^{-1}k(3)$

[3 marks]

[3 markah]

Answer/Jawapan :

(a)

(b)

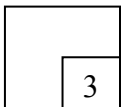
2

3. Given that the functions $f : x \rightarrow ax + b$, $g^{-1} : x \rightarrow \frac{x+5}{2}$ and $fg^{-1} : x \rightarrow 4 + 3x$.

Find the value of a and of b .

[3 marks]

Diberi fungsi-fungsi $f : x \rightarrow ax + b$, $g^{-1} : x \rightarrow \frac{x+5}{2}$ and $fg^{-1} : x \rightarrow 4 + 3x$.

Cari nilai a dan nilai b .

[3 markah]

Answer/Jawapan :

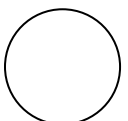
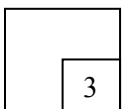
3

For
examiner's
use only

SULIT

3472/1

4. Find the range of values of x for $2x(x+5) \geq x+5$.

[3 marks]

Cari julat nilai x bagi $2x(x+5) \geq x+5$

[3 markah]

Answer/Jawapan :

4

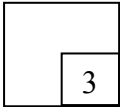

3

5. The quadratic equation $px - 1 = 3x^2 - x + p$, where p is a constant, has no roots.
Find the range of values of p .

[3 marks]

Persamaan kuadratik $px - 1 = 3x^2 - x + p$, dengan keadaan p ialah pemalar, tidak mempunyai punca.

Cari julat nilai p .

[3 markah]

Answer/Jawapan :

5

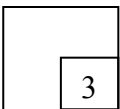

3

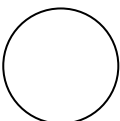

SULIT

3472/1

For
examiner's
use only

6. Diagram 6 shows the graph of a quadratic function for $f(x) = 2(x - m)^2 - 3$.
Rajah 6 menunjukkan graf fungsi kuadratik bagi $f(x) = 2(x - m)^2 - 3$.

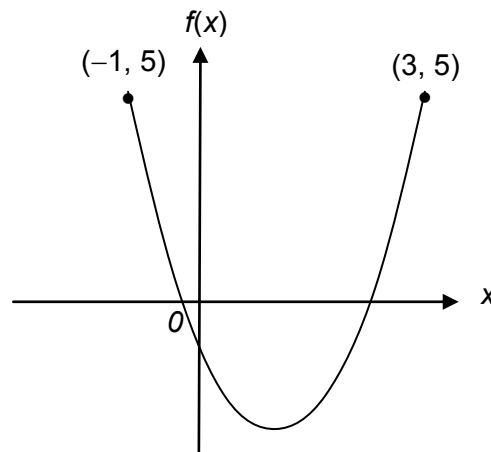

Diagram 6
Rajah 6

Find
Cari

- (a) the value of m ,
nilai m ,
- (b) the equation of the axis of symmetry,
persamaan paksi simetri,
- (c) the coordinates of the minimum point.
koordinat-koordinat titik minimum.

[3 marks]
[3 markah]

Answer/Jawapan :

(a)

(b)

(c)

6

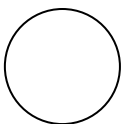
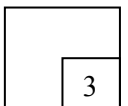

[Lihat halaman sebelah
SULIT

For
examiner's
use only

SULIT

7. Solve the equation $\sqrt{25^{x+2}} = \frac{1}{625^{x-1}}$.

[3 marks]

Selesaikan persamaan $\sqrt{25^{x+2}} = \frac{1}{625^{x-1}}$.

[3 markah]

Answer/Jawapan :

7

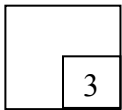

8. Solve the equation $\log_9 x + \log_{81} 3x = -1$.

[4 marks]

Selesaikan persamaan $\log_9 x + \log_{81} 3x = -1$.

[4 markah]

Answer/Jawapan :

8

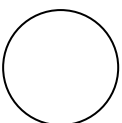
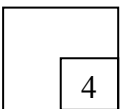

SULIT**3472/1**

9. The first three terms of an arithmetic progression are $2h - 4$, $5h - 1$ and $6h + 4$.
Tiga sebutan pertama suatu jajang aritmetik adalah $2h - 4$, $5h - 1$ dan $6h + 4$.

Find,
Cari,

- (a) the value of h ,
nilai h ,
- (b) the sum of next 20 terms after the third term.
hasil tambah 20 sebutan berikutnya selepas sebutan ketiga.

[4 marks]

[4 markah]

Answer/Jawapan :

(a)

(b)

*For
 examiner's
 use only*

9

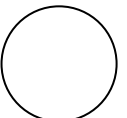
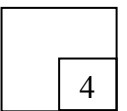

For
examiner's
use only

SULIT

10. The sum to infinity of a geometric progression is 3 and the sum of its first two terms is $2\frac{2}{3}$.

Hasil tambah hingga sebutan ketakterhinggaan bagi jangjang geometri ialah 3 dan hasil tambah dua sebutan pertama ialah $2\frac{2}{3}$.

Find the common ratio ($r < 0$) and the first term.

Cari nilai nisbah sepunya ($r < 0$) dan sebutan pertama.

[4 marks]

[4 markah]

Answer/Jawapan

10



11. Aiman saves RM 300 from his salary in a certain month. In each succeeding month, he saves RM 50 more than the previous month.

Aiman telah membuat simpanan RM 300 daripada wang gajinya pada bulan tertentu. Pada bulan yang berikutnya, beliau telah menambah simpanannya sebanyak RM 50 melebihi bulan sebelumnya.

Calculate the amount of his saving in 3 years.

Hitungkan jumlah simpanan beliau dalam masa 3 tahun.

[3 marks]

[3 markah]

Answer/Jawapan :

11

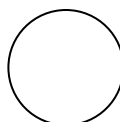

12. The variables x and y are related by the equation $x + \frac{p}{x} = qy$. A straight line graph is obtained by plotting xy against x^2 , as shown in Diagram 12, where p and q are constants.

Pemboleh ubah x dan y dihubungkan oleh persamaan $x + \frac{p}{x} = qy$. Graf garis lurus diperolehi dengan memplot xy melawan x^2 , seperti ditunjukkan pada Rajah 12, dengan keadaan p dan q ialah pemalar.

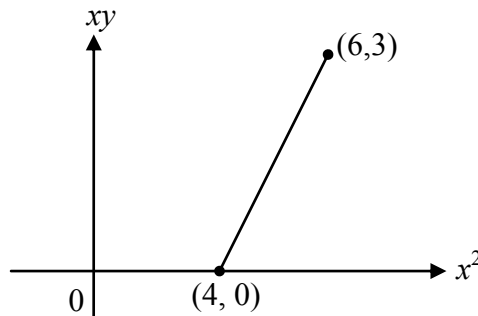

Diagram 12
Rajah 12

Find the value of p and of q .
Cari nilai p dan nilai q .

[3 marks]
[3 markah]

Answer/Jawapan :

12

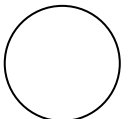
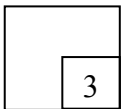

[Lihat halaman sebelah
SULIT

For
examiner's
use only

SULIT

13. In Diagram 13, the straight line PQ has an equation $\frac{x}{8} + \frac{y}{2t} = 1$ with gradient of $-\frac{1}{4}$. PQ intersects the x -axis at point P and intersects the y -axis at point Q .

Dalam Rajah 13, garis lurus PQ mempunyai persamaan $\frac{x}{8} + \frac{y}{2t} = 1$ dengan kecerunan $-\frac{1}{4}$. PQ menyilang paksi- x di titik P dan menyilang paksi- y di titik Q .

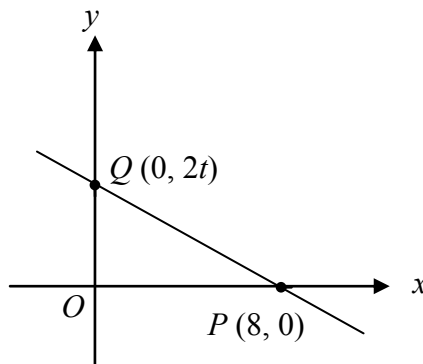

Diagram 13
Rajah 13

Find,
Cari,

- (a) the value of t ,
nilai bagi t
- (b) the equation of the straight line that passes through Q and is perpendicular to PQ .
persamaan garis lurus yang melalui Q dan berserenjang dengan PQ .

[4 marks]

[4 markah]

Answer/Jawapan :

(a)

(b)

13

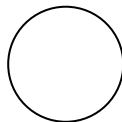
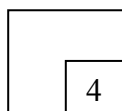

14. Given that the point $A(-4,2)$ and $B(4,6)$. The point $P(-2,3)$ lies on the straight line of AB such that $AP : PB = m : n$.

Diberi titik $A(-4,2)$ dan $B(4,6)$. Titik $P(-2,3)$ terletak pada garislurus AB dengan keadaan $AP : PB = m : n$.

Find the value of m and of n .

Cari nilai m dan nilai n .

[3 marks]

[3 markah]

Answer/Jawapan :

14

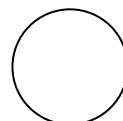
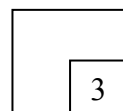

SULIT

For
examiner's
use only

15. Diagram 15 shows triangle ABC . K is a point on BC such that $BK : KC = 1 : 2$.

Given that $\overrightarrow{AB} = 3\underline{x}$ and $\overrightarrow{AC} = 6\underline{y}$.

Rajah 15 menunjukkan sebuah segitiga ABC . K ialah titik yang terletak digaris BC berkeadaan $BK : KC = 1 : 2$. Diberi bahawa $\overrightarrow{AB} = 3\underline{x}$ dan $\overrightarrow{AC} = 6\underline{y}$.

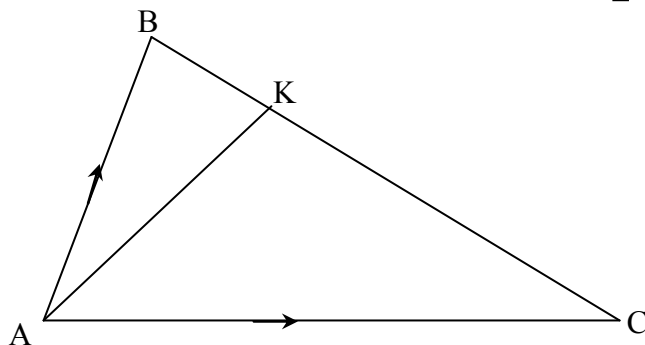

Diagram 15
Rajah 15

Express in terms of \underline{x} and \underline{y} .

Ungkapkan dalam sebutan \underline{x} dan \underline{y} ,

(a) \overrightarrow{BC}

(b) \overrightarrow{AK}

[3 marks]
[3 markah]

Answer/Jawapan :

(a)

(b)

15

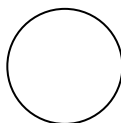
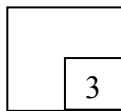

16. Diagram 16 shows the vector \overrightarrow{OP} and \overrightarrow{OQ} .

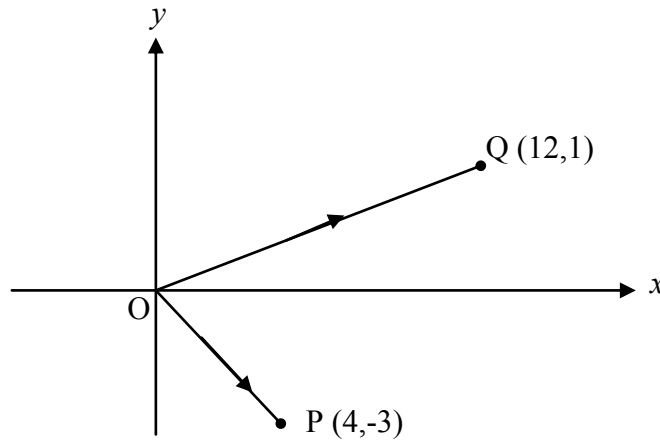

Diagram 16
Rajah 16

Given that $O(0,0)$, $P(4,-3)$ and $Q(12,1)$, find in terms of \hat{i} and \hat{j} ,

Diberi bahawa $O(0,0)$, $P(4,-3)$ and $Q(12,1)$, cari dalam sebutan \hat{i} dan \hat{j} ,

(a) \overrightarrow{PQ}

(b) the unit vector in the direction of \overrightarrow{PQ} .

vektor unit dalam arah \overrightarrow{PQ} .

[3 marks]
[3 markah]

Answer/Jawapan :

(a)

(b)

16

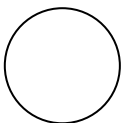

[Lihat halaman sebelah
SULIT

SULIT

17. Diagram 17 shows sector OAB and sector OCD, with centre O .
Rajah 17 menunjukkan sector OAB dan sektor OCD, yang berpusatkan O.

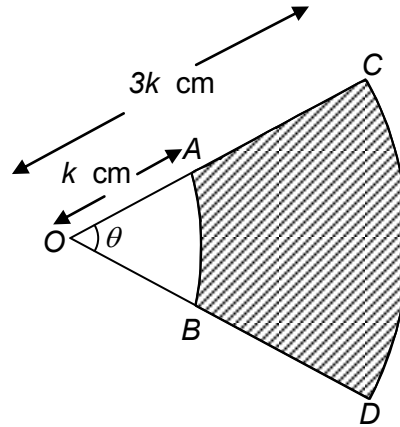

Diagram 17
Rajah 17

Given that $\theta = 0.8 \text{ rad}$ and the area of sector OAB is 40 cm^2 .

Diberi bahawa $\theta = 0.8 \text{ rad}$ dan luas bagi sektor OAB is 40 cm^2 .

Find the value of

Cari nilai bagi

- (a) k
- (b) the perimeter of the shaded region.
perimeter kawasan yang berlorek

[4 marks]
[4 markah]

Answer/Jawapan :

(a)

(b)

17

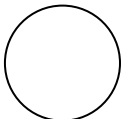
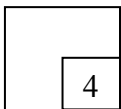

SULIT**3472/1***For
examiner's
use only*

18. Given that $\sin A = -\frac{12}{13}$ and $\cos B = \frac{4}{5}$, where A and B are in the same quadrant. Find the value of $\sin(A - B)$.

[2 marks]

Diberi $\sin A = -\frac{12}{13}$ dan $\cos B = \frac{4}{5}$, dimana A dan B berada dalam sukuan yang sama. Cari nilai $\sin(A - B)$.

[2 markah]

Answer/Jawapan :

18

2

19. Given that $\int_1^2 f(x) dx = 5$. Find the value of $\int_2^1 (x + f(x)) dx$.

[3 marks]

Diberi $\int_1^2 f(x) dx = 5$. Cari nilai $\int_2^1 (x + f(x)) dx$.

[3 markah]

Answer/Jawapan :

19

3

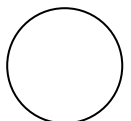

[Lihat halaman sebelah
SULIT

For
examiner's
use only

SULIT

20. Given that $y = x^2(x^3 + 4)^3$, find the value of $\frac{dy}{dx}$ when $x = -1$.

[3 marks]

Diberi $y = x^2(x^3 + 4)^3$, cari nilai $\frac{dy}{dx}$ apabila $x = -1$.

[3 markah]

Answer/Jawapan :

20

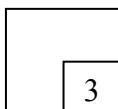

21. The volume, $V \text{ cm}^3$ of water in a vessel is given by $V = 450h - 45h^2$, where $h \text{ cm}$ is the height of the water in the vessel.
Isipadu, $V \text{ cm}^3$ air dalam takungan diberi oleh $V = 450h - 45h^2$, dimana $h \text{ cm}$ ialah tinggi air dalam takungan itu.

Calculate
Kira

- (a) the value of h when V is maximum.
nilai h apabila V maksimum.
- (b) the maximum volume of water in the vessel.
isipadu maksimum air dalam takungan itu

[3 marks]
[3 markah]

Answer/Jawapan :

(a)

21

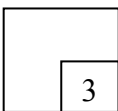

(b)

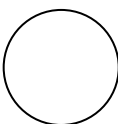

SULIT**3472/1***For
examiner's
use only*

22. A set of positive integers consists of 3, 7, p , 5, 1. Given that the mean for the set of data is 5.

Satu set integer positif mengandungi 3, 7, p , 5, 1. Diberi min untuk set data ini ialah 5.

Find

Cari

- (a) the value of p .
nilai p .
- (b) the variance for the set of data.
varian bagi set data ini.

[3 marks]

[3 markah]

Answer/Jawapan :

(a)

(b)

22

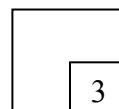

23. (a) Three letters are chosen from the word "BERHAD". Calculate the number of different ways in which the three letters can be chosen if there is no restriction.

Tiga huruf dipilih daripada perkataan "BERHAD". Hitung bilangan cara berlainan huruf ini boleh dipilih jika tiada sebarang syarat dikenakan.

- (b) In how many ways can the word "BERHAD" be arranged if the vowel are arranged side by side? .

Dalam berapa carakah huruf-huruf dalam perkataan "BERHAD" dapat disusun jika huruf vokal hendaklah disusun sebelah menyebelah.

[3 marks]

[3 markah]

Answer/Jawapan :

(a)

(b)

23

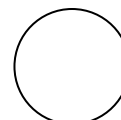
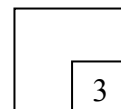

[Lihat halaman sebelah

SULIT

For
examiner's
use only

SULIT

24. The probability that Rajesh qualifies for the final 400m event is $\frac{1}{4}$ while the probability that Razali qualify is $\frac{1}{3}$.

Kebarangkalian bahawa Rajesh layak pertandingan akhir acara 400m ialah $\frac{1}{4}$ manakala kebarangkalian untuk Razali layak ialah $\frac{1}{3}$.

Find the probability that
Hitung kebarangkalian bahawa

- (a) both of them did not qualify for the final.
kedua-dua mereka tidak layak pertandingan akhir.
- (b) only one of them qualifies for the final.
hanya salah seorang daripada mereka layak pertandingan akhir.

[3 marks]

[3 markah]

Answer/Jawapan :

(a)

(b)

24

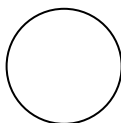
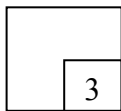

SULIT**3472/1***For
examiner's
use only*

25. Diagram 25 shows a normal distribution graph.
Rajah 25 menunjukkan graf taburan normal .

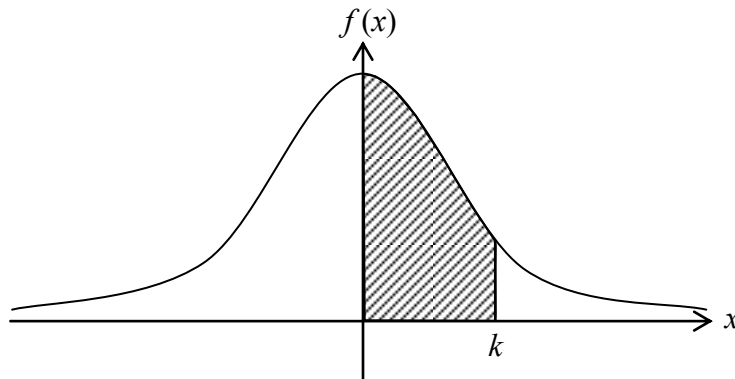

Diagram 25
Rajah 25

X is a continuous random variable which is normally distributed with a mean of 55 kg and a standard deviation of 3 kg.
Given that the area of the shaded region is 0.3485.

*X ialah pembolehubah rawak selanjar yang tertabur secara normal dengan min 55 kg dan sisihan piawai 3 kg.
Diberi bahawa luas bagi kawasan berlorek ialah 0.3485.*

Find
Cari

- (a) $P(X \geq k)$
(b) the value of k .
nilai bagi k .

[4 marks]
[4 markah]

Answer/Jawapan :

- (a)

(b)

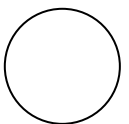
25

**END OF QUESTION PAPER
KERTAS SOALAN TAMAT**

INFORMATION FOR CANDIDATES
MAKLUMAT UNTUK CALON

1. This question paper consists of **25** questions
Kertas soalan ini mengandungi 25 soalan
2. Answer **all** questions.
*Jawab **semua** soalan*
3. Write your answers in the spaces provided in the question paper.
Tulis jawapan anda dalam ruang yang disediakan dalam kertas soalan.
4. Show your working. It may help you to get marks.
Tunjukkan langkah-langkah penting dalam kerja mengira anda. Ini boleh membantu anda untuk mendapatkan markah.
5. If you wish to change your answer, cross out the answer that you have done. Then write down the new answer.
Sekiranya anda hendak menukar jawapan, batalkan jawapan yang telah dibuat. Kemudian tulis jawapan yang baru.
6. The diagrams in the questions provided are not drawn to scale unless stated.
Rajah yang mengiringi soalan tidak dilukis mengikut skala kecuali dinyatakan.
7. The marks allocated for each question are shown in brackets.
Markah yang diperuntukkan bagi setiap soalan ditunjukkan dalam kurungan.
8. A list of formulae is provided on pages 3 to 5.
Satu senarai rumus disediakan di halaman 3 hingga 5.
9. A booklet of four-figure mathematical tables is provided.
Sebuah buku sifir matematik empat angka disediakan.
10. You may use a non-programmable scientific calculator.
Anda dibenarkan menggunakan kalkulator saintifik yang tidak boleh diprogram.
11. Hand in this question paper to the invigilator at the end of the examination.
Serahkan kertas soalan ini kepada pengawas peperiksaan di akhir peperiksaan.